

t.0845 0524442

Suspended lights - Saturno



Dimensions

700mm dia x 220mm

x 1200mm drop

Why Use This

-Striking blown Murano glass with a nickel mirror finish.

-Clever clutch mechanism for precise hanging heights, the lamps are tungsten for dimming, and a low energy (non dimming) version is also available

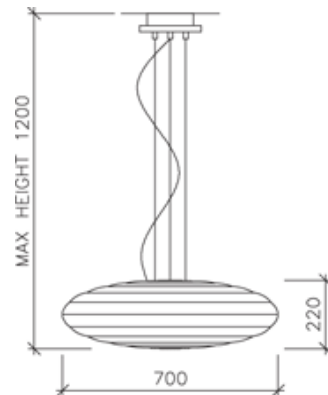

Product Code L80.039

Construction Blown glass

Emergency Available? N

Colours / Finish Blown glass in white, amber
or chrome finish

Light Source & Voltage Tungsten max 100w,
(Suitable for 11w low energy retro-fit lamps)

Detail Lighting Limited
Warrington Farm Design Office
Olney (A509)
Bucks
MK46 4HN

Tel: 0845 052 4442

Fax: 0845 052 4443

Email: sales@detaillighting.co.uk

